

AARON

Pio & Tito Toso | 2020



AARON

Pio & Tito Toso | 2020

It was born generous, attentive and dynamic. You could call it a friend, one of the family. It was born double, like the double "A" in its name. AARON, a stool and a table all in one. It is an elegant and functional solution for all contexts, reducing space and highlighting privacy. It has an embracing seat and a metal core giving rise to a column that becomes a swivel tabletop. At different heights, also with a footrest, AARON is the ideal solution for all work, meeting and relaxation needs. The designers who started this small revolution in the world of Lapalma stools are the Venetian brothers PIO&TITOTOSO. A story of complicity and understanding. A dual story. A great idea.



AARON

Pio & Tito Toso | 2020



| S436 stool with swivel table top h52

Stool with base in powder coated steel. Swivel seat upholstered with fire retardant moulded foam covered with fabric, ecoleather or leather and off-centre pivoting tablet. Felt under the base. Also available with small base for floor fixing.

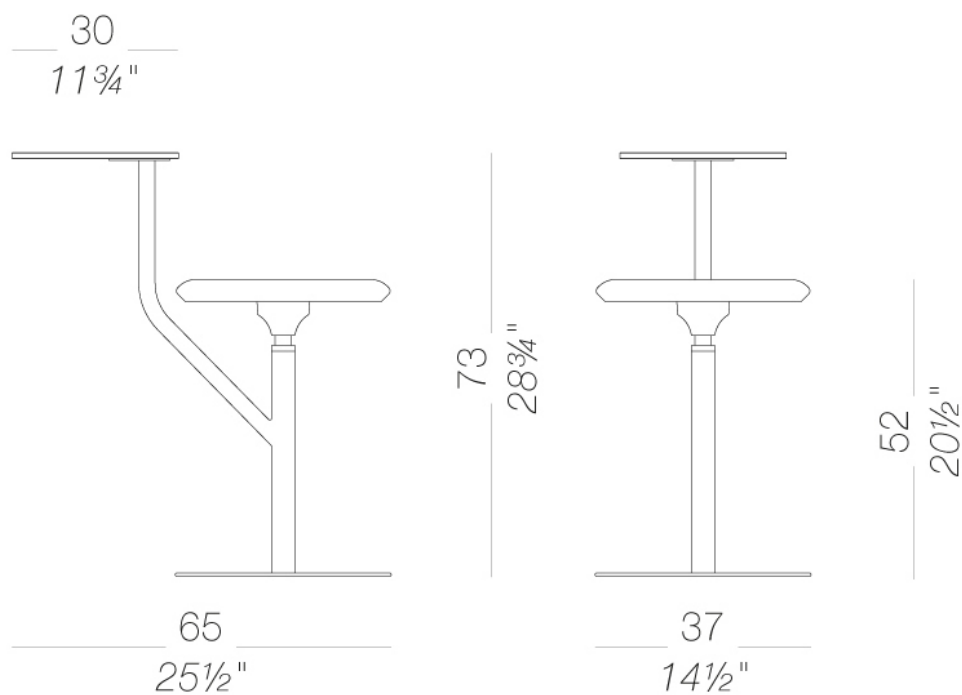

AARON

Pio & Tito Toso | 2020

| S440 stool with swivel table top h60

Stool with base in powder coated steel. Swivel seat upholstered with fire retardant moulded foam covered with fabric, ecoleather or leather and off-centre pivoting tablet. Felt under the base. Also available with small base for floor fixing.

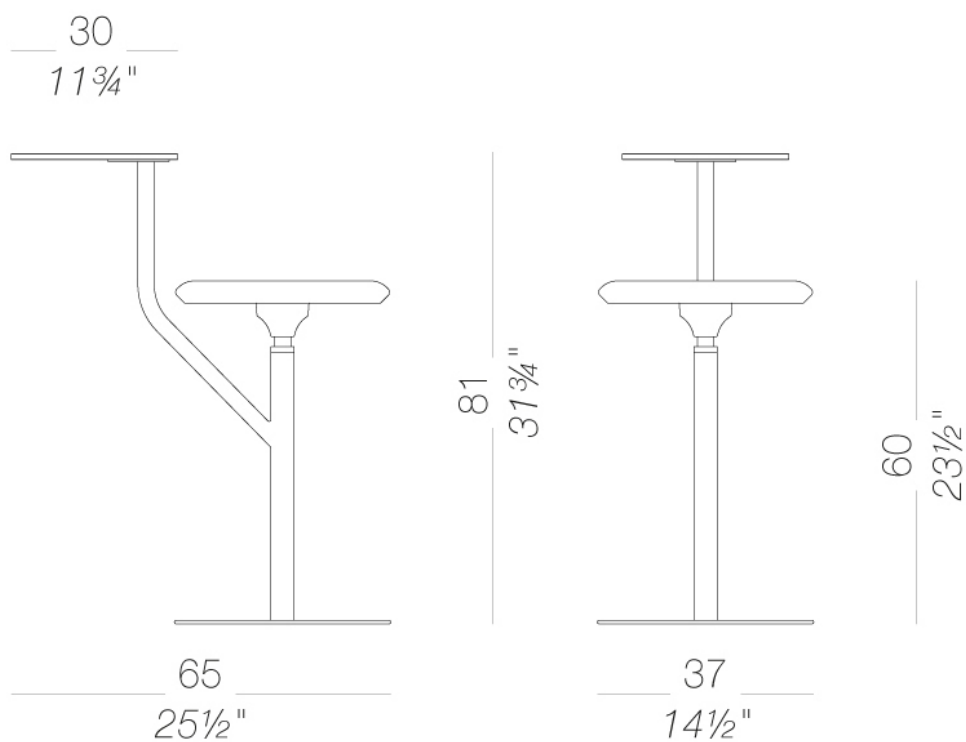

AARON

Pio & Tito Toso | 2020

| S444 stool with swivel table top h78

Stool with base and footrest in powder coated steel. Swivel seat upholstered with fire retardant moulded foam covered with fabric, ecoleather or leather and off-centre pivoting tablet. Felt under the base. Also available with small base for floor fixing.



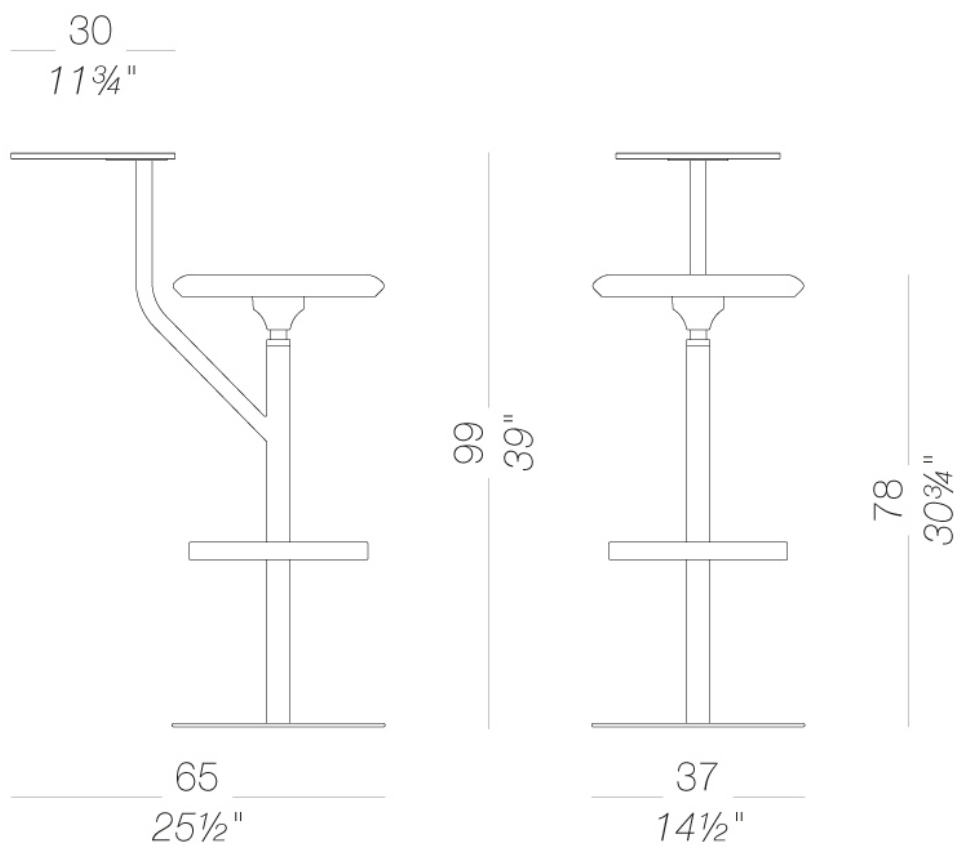





TEST EN 1728:2012 AC:2013 - EN 16139:2013 - L2



AARON

Pio & Tito Toso | 2020







frame

							
powder coating black 1 Colors	powder coating white 1 Colors	powder coating perla 1 Colors	powder coating celeste 1 Colors	powder coating mattone 1 Colors	powder coating caffè 1 Colors	powder coating oliva 1 Colors	powder coating tortora 1 Colors

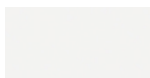
seat

							
wood natural ash 1 Colors	wood black open pore 1 Colors	fabric Hallingdal 65 58 Colors	fabric Canvas 2 45 Colors	fabric Steelcut Trio 3 54 Colors	fabric Remix 3 72 Colors	fabric Clara 2 24 Colors	fabric Fiord 2 39 Colors
							
fabric Divina MD 27 Colors	fabric Divina Melange 3 38 Colors	fabric Tonica 2 39 Colors	fabric Medley 37 Colors	fabric Maya 43 Colors	fabric Jet 66 Colors	fabric Lapalma Smart 18 Colors	fabric Capture 43 Colors
							
fabric Crisp 40 Colors	fabric Nattè 23 Colors	fabric Iris 24 Colors	fabric Steelcut 2 37 Colors	soft-leather soft-leather 7 Colors	ecoleather GRIMM FR 24 Colors	ecoleather Valencia 59 Colors	

top

							
powder coating black 1 Colors	powder coating white 1 Colors	powder coating perla 1 Colors	powder coating celeste 1 Colors	powder coating mattone 1 Colors	powder coating caffè 1 Colors	powder coating oliva 1 Colors	powder coating tortora 1 Colors

consult the portfolio for the range of colors, fabrics, eco-leather, soft-leather.

use and maintenance instructions

Clean all parts in wood, leather, fabric and metal with a damp cloth or a diluted neutral cleaner. Do not use cleaners with alcohol, bleach, solvent or abrasive products. Any liquid spilt on the product must be wiped up immediately. When lifting or moving the product, hold it on the structure and not under the seat. The product should not be subjected to unbalanced weights, as it is designed for a proper rest on the foothold (on four legs or on the base). Our company relieves from any responsibility in case of damage caused to fragile floors. Avoid any improper use of the product: do not step on the product, on the footrest or on the armrests. Avoid any movements that could compromise the proper functionality of the product or the safety of the users. Wood and leather, being natural materials, could be easily damaged. Small impurities or imperfections are within quality standard range. Do not expose the product to weather conditions or atmospheric agents, nor to heat sources over 40°C. Also products for outdoor use could be afflicted by atmospheric agents. The product could undergo possible exterior changes due to particular exposure to heat, humidity and saltiness. An appropriate and frequent maintenance and cleaning of the product enhances its durability. The product could change colour and shade, if exposed to direct sunlight. Maintenance has to be carried out by experienced staff. Dispose of the package only after assembling the product, in order to avoid the loss of ironmongery and components. Once the product has been dismantled, the product itself or its components must be given to the public garbage disposal system, according to the legislation in force.

AARON

Pio & Tito Toso | 2020





Pio & Tito Toso | 2020

Trees can sense the warm season, as they start to grow again and each branch produces a new one. Also AARON, with its echoing vowels, announces the arrival of spring and summer, and the classic stool sprouts a side table. A single line, elegant and fluid, like only natural lines can be. This original combined seat and top adds extra functions, ensuring privacy and comfort in a very small space, perhaps because it was created thanks to the talent of two brothers, Pio and Tito Toso, or maybe because it was born in Venice, a city doubled in its waters. It has a metal column, at different heights, with a footrest and base that can be fixed to the floor. The seat is in Iroko wood. For Lapalma, it is a new outdoor masterpiece. For nature, it is one of her most beautiful designs.



ES436 | outdoor stool with swivel table top h52

Stool with base in stainless steel 304 polyester powder coated. Swivel seat in solid Iroko wood and off-centre pivoting tablet in aluminium polyester powder coated. Rubber glides under the base.

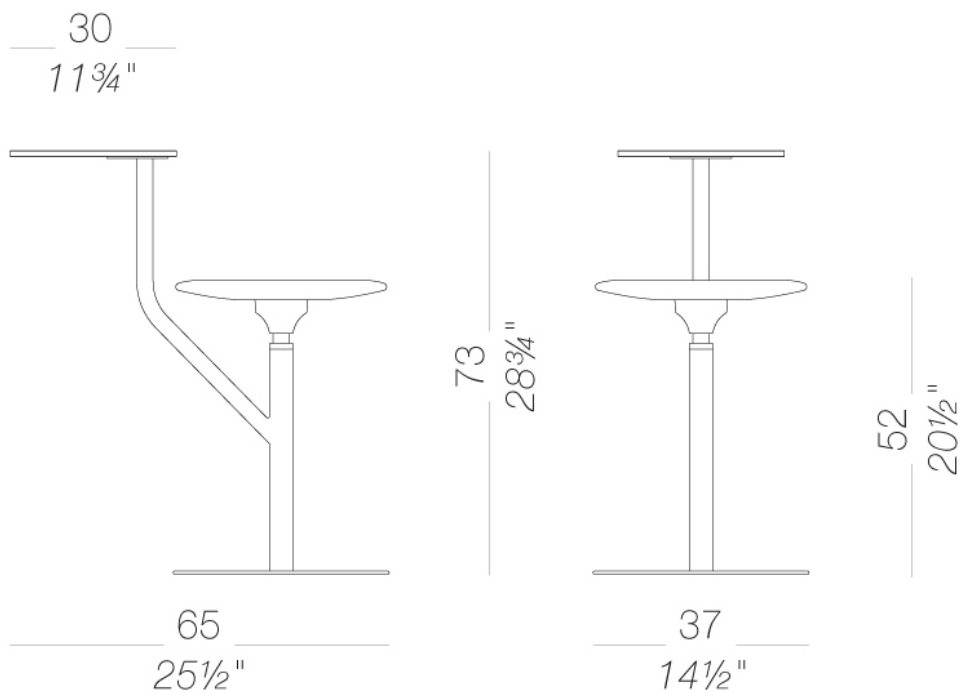

AARON

Pio & Tito Toso | 2020

ES440 | outdoor stool with swivel table top h60 ☀️

Stool with base in stainless steel 304 polyester powder coated. Swivel seat in solid Iroko wood and off-centre pivoting tablet in aluminium polyester powder coated. Rubber glides under the base.

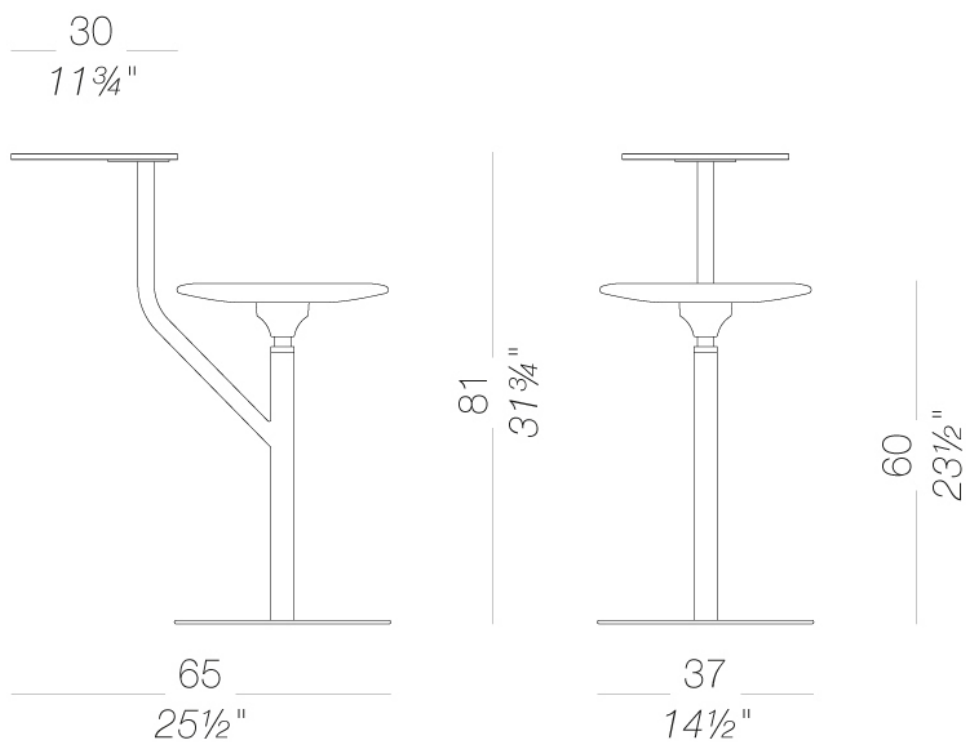

AARON

Pio & Tito Toso | 2020





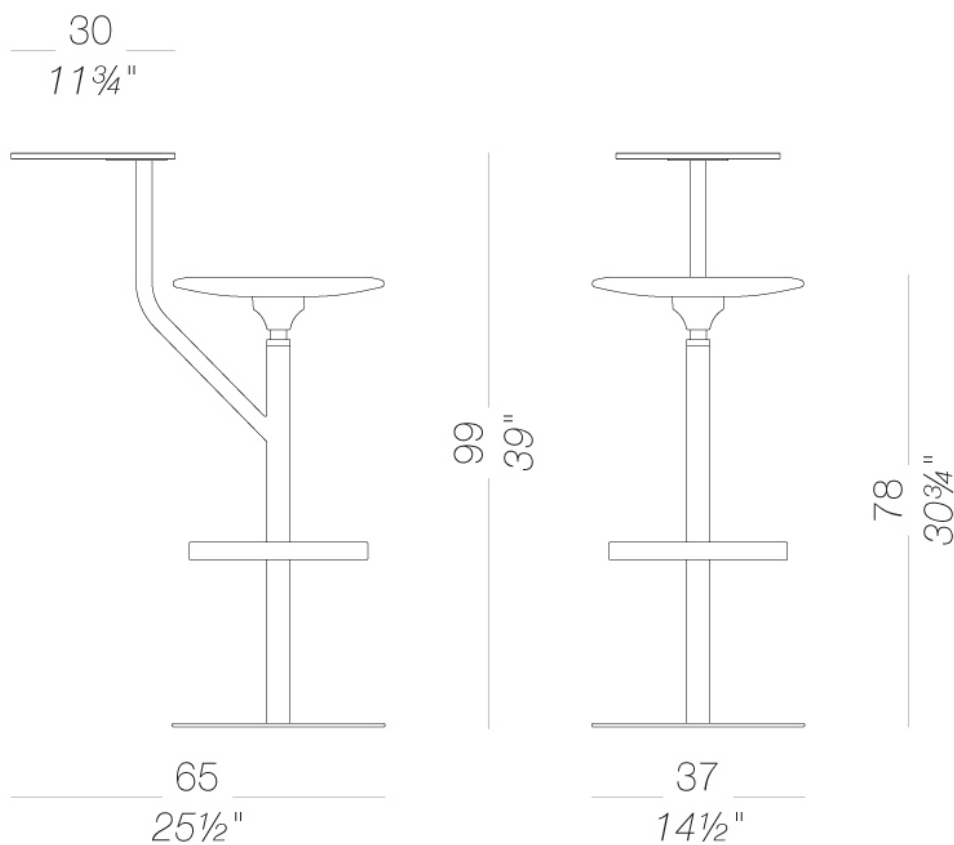

ES444 | outdoor stool with swivel table top h78 ☀️

Stool with base in stainless steel 304 polyester powder coated. Swivel seat in solid Iroko wood and off-centre pivoting tablet in aluminium polyester powder coated. Rubber glides under the base.

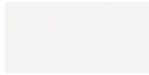
TEST EN 1728:2012 AC:2013 - EN 16139:2013 - L2



frame







							
powder coating black 1 Colors	powder coating white 1 Colors	powder coating perla 1 Colors	powder coating celeste 1 Colors	powder coating mattone 1 Colors	powder coating caffè 1 Colors	powder coating oliva 1 Colors	powder coating tortora 1 Colors

seat

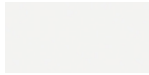

wood
iroko
1 Colors

top

							
powder coating black 1 Colors	powder coating white 1 Colors	powder coating perla 1 Colors	powder coating celeste 1 Colors	powder coating mattone 1 Colors	powder coating caffè 1 Colors	powder coating oliva 1 Colors	powder coating tortora 1 Colors

consult the folder of materials for the range of colors

use and maintenance instructions

Iroko is a naturally weather-resistant wood, as it is rich in tannins, making it ideal for outdoor use. When exposed to light, the colour gradually darkens and every variation in grain shade from brown, chestnut brown to dark grey are characteristic of this wood type. The presence of different grain patterns, knots and natural imperfections guarantee the naturalness of the wood and do not constitute any grounds for claims. To prolong the life of Iroko components, clean surfaces regularly, dry them with a clean cloth and remove any stagnant water. To prevent drying out of the surface, small cracks and/or the formation of mould, we recommend treating the wood once a year with specific products for the maintenance of solid wood (recommended product "OLTS7" water-based natural oil from www.brava.it). Do not use detergents containing bleach, hydrochloric acid or products containing chloride on any metal parts. Salt, limescale or acid (from coffee, wine, orange juice, tomato juice, lemon, etc.) may discolour stainless steel parts if they are not promptly cleaned. Products or parts made of stainless steel used near the sea or in interior fittings of swimming pools require more frequent cleaning to remove chloride deposits and prevent corrosion and chemical attack of the external surface. Stains on stainless steel surfaces must be promptly cleaned. If left for a long time they can become permanent.

To prolong the life of the product, clean the surfaces regularly, dry them with a clean cloth and remove any stagnant water, especially if exposed in locations with a high level of humidity or a marine climate.

When not in use, we recommend storing in sheltered places and covering with waterproof protection. In this case, it is advisable to remove the cover and ventilate the product frequently and regularly to avoid the onset of any mould or stains due to damp.

THE WARRANTY WILL NOT COVER DEFECTS OR IMPERFECTIONS RESULTING FROM THE PASSAGE OF TIME OR TO WEAR AND TEAR DUE TO THE NORMAL USE OF THE PRODUCT.