

ADD SYSTEM

Francesco Rota | 2016

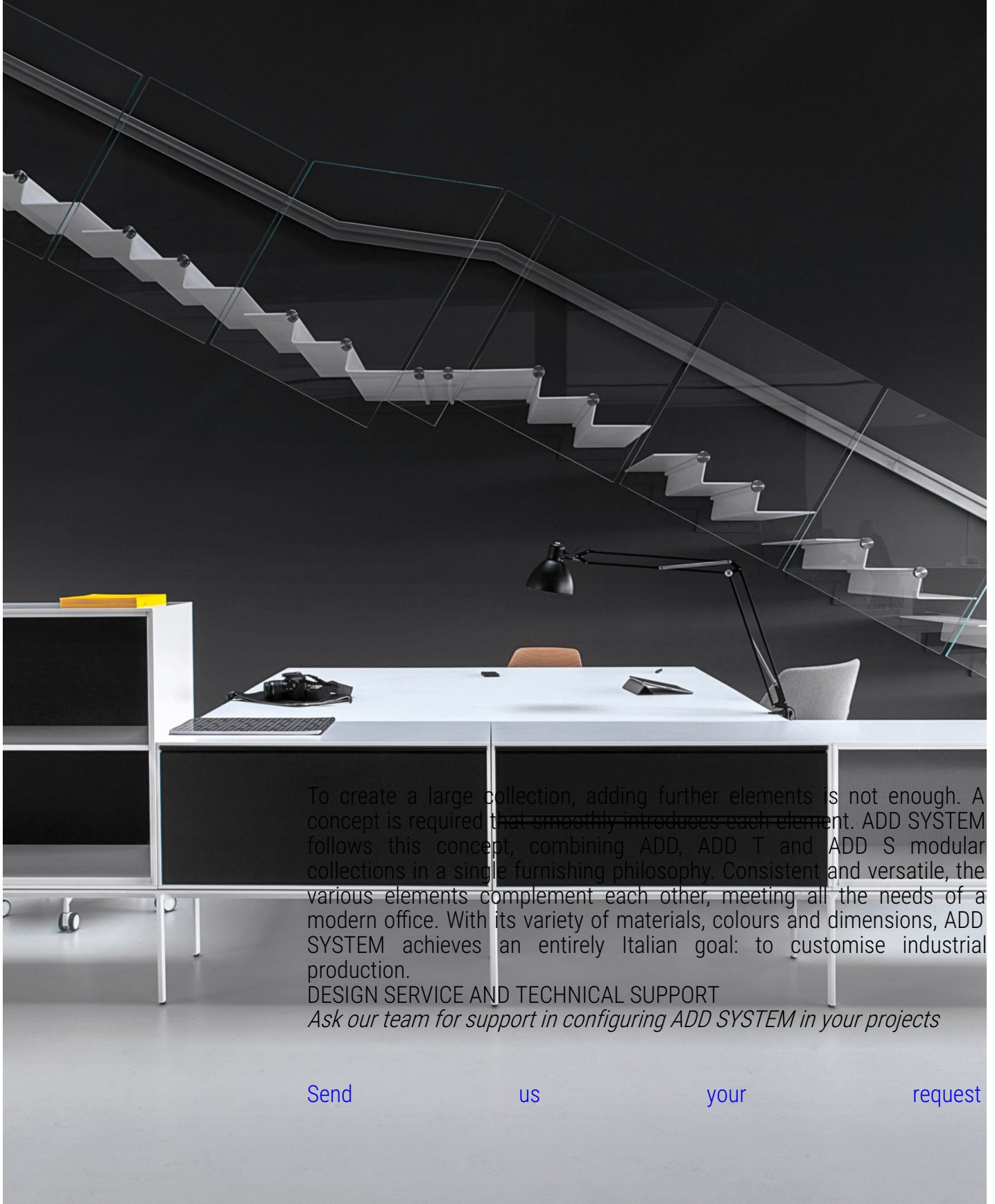

To create a large collection, adding further elements is not enough. A concept is required that smoothly introduces each element. ADD SYSTEM follows this concept, combining ADD, ADD T and ADD S modular collections in a single furnishing philosophy. Consistent and versatile, the various elements complement each other, meeting all the needs of a modern office. With its variety of materials, colours and dimensions, ADD SYSTEM achieves an entirely Italian goal: to customise industrial production.

DESIGN SERVICE AND TECHNICAL SUPPORT

Ask our team for support in configuring ADD SYSTEM in your projects

Send us your request

ADD SYSTEM

Francesco Rota | 2012

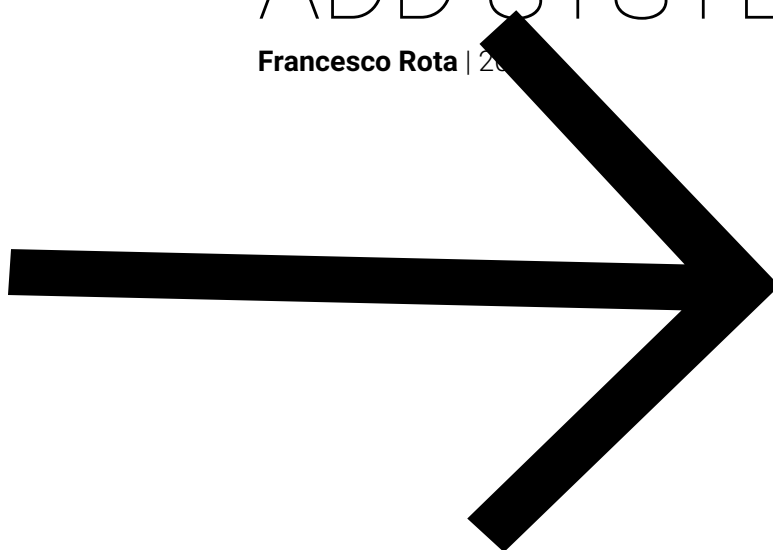



L_shape

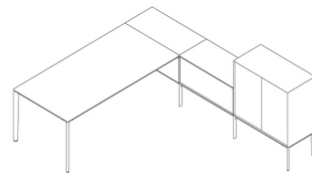

L_shape

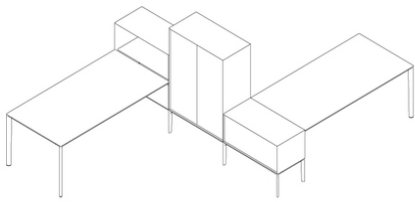

S_shape

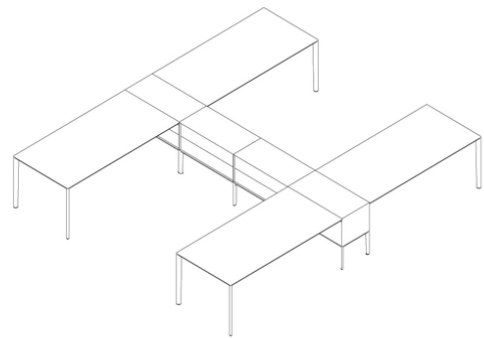

H_shape

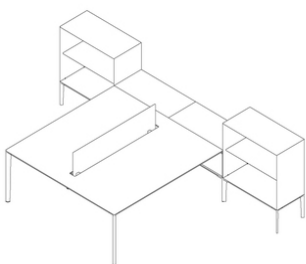

T_shape

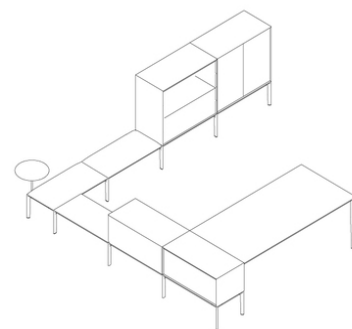

U_shape — executive

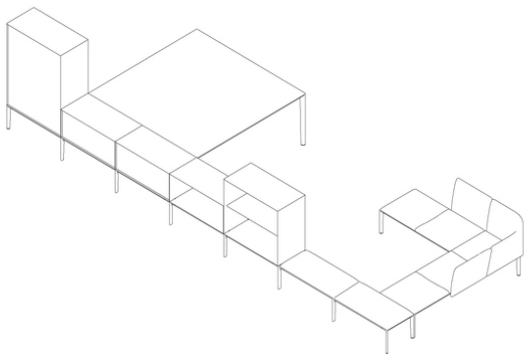

Meeting

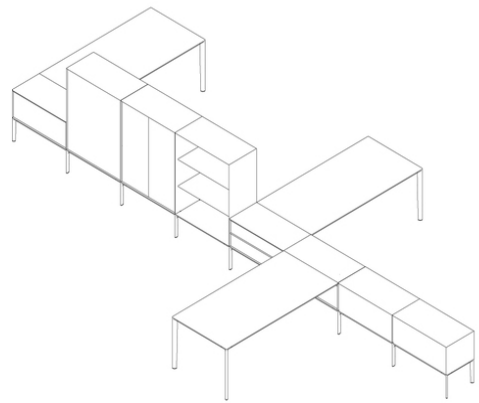

Asymmetrical workstation 1

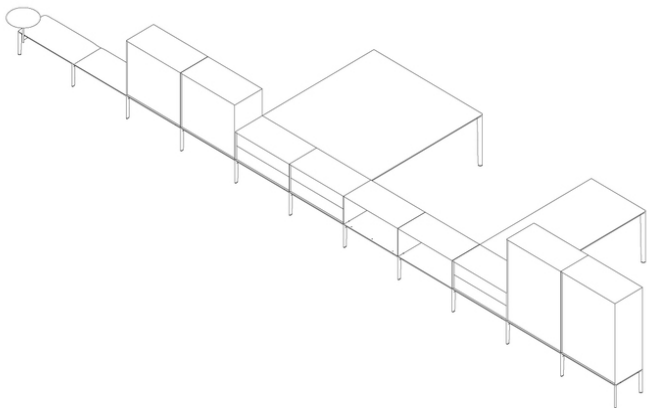

Asymmetrical workstation 2

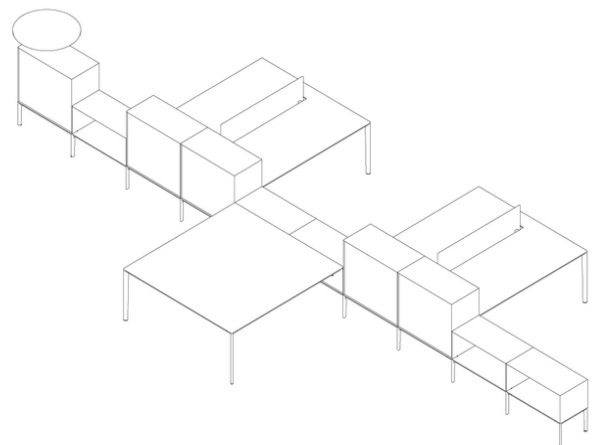

Asymmetrical workstation 3

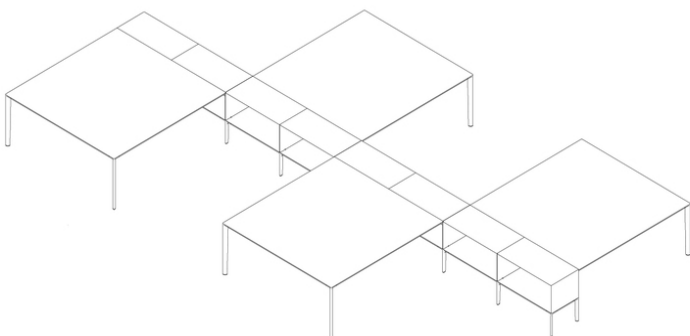

Symmetrical workstation – square

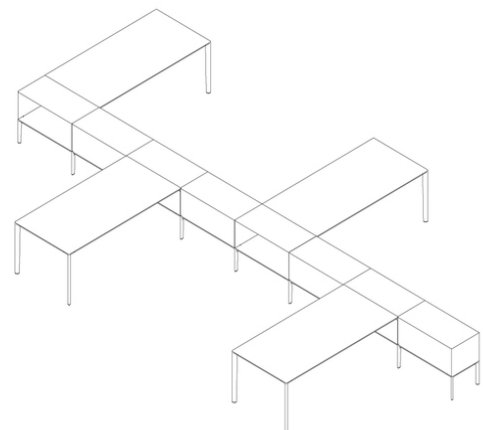

Symmetrical workstation – rectangular

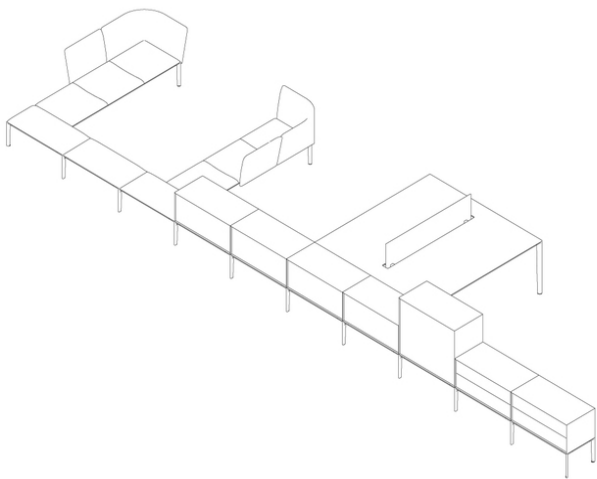

Complex office — small

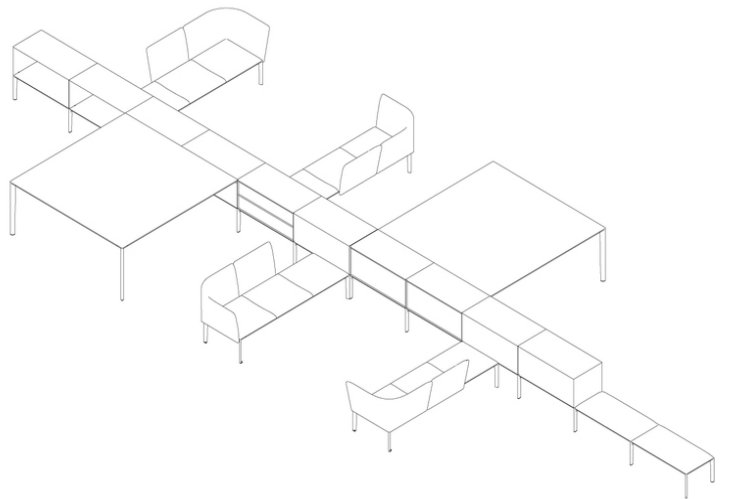

Complex office symmetrical — medium

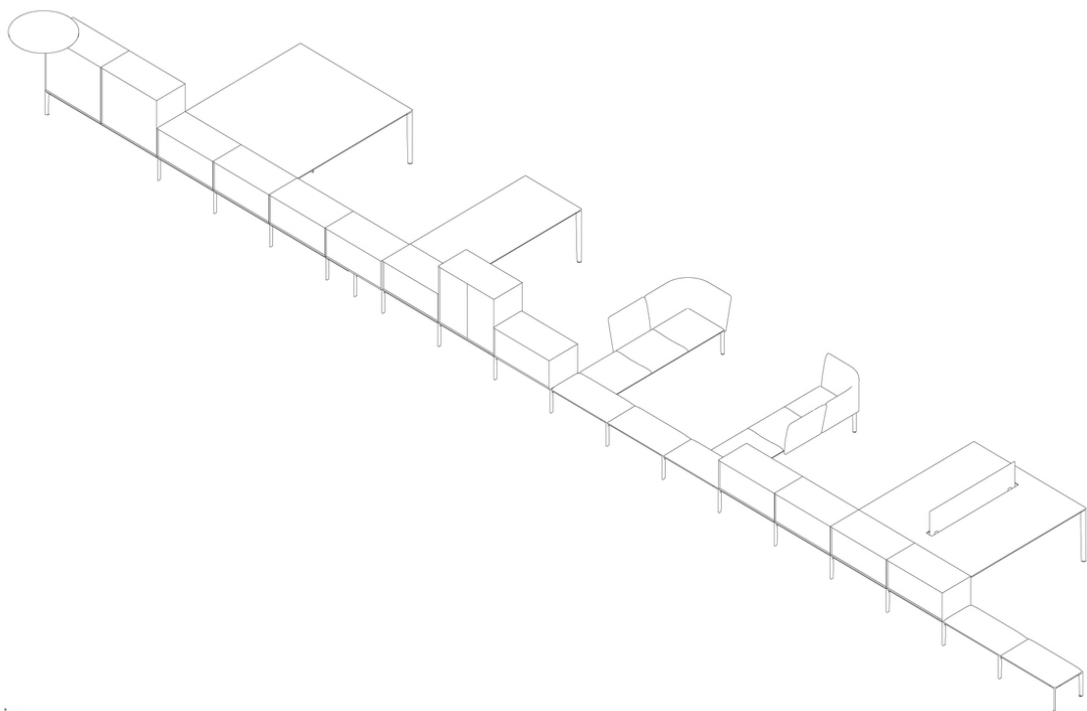

Complex office — big

ADD SYSTEM

Francesco Rota | 2016

Modular system of ADD T tables linked with ADD S storage units, which offer several furniture solutions for the office. Frame in aluminium with tops in HPL Fenix®, or in plywood blanché oak veneered or black open pore. Storage units in powder coated metal, with shelves, drawers, backs and doors in several finishes. ADD SYSTEM can be combined with the seating system ADD.

tops

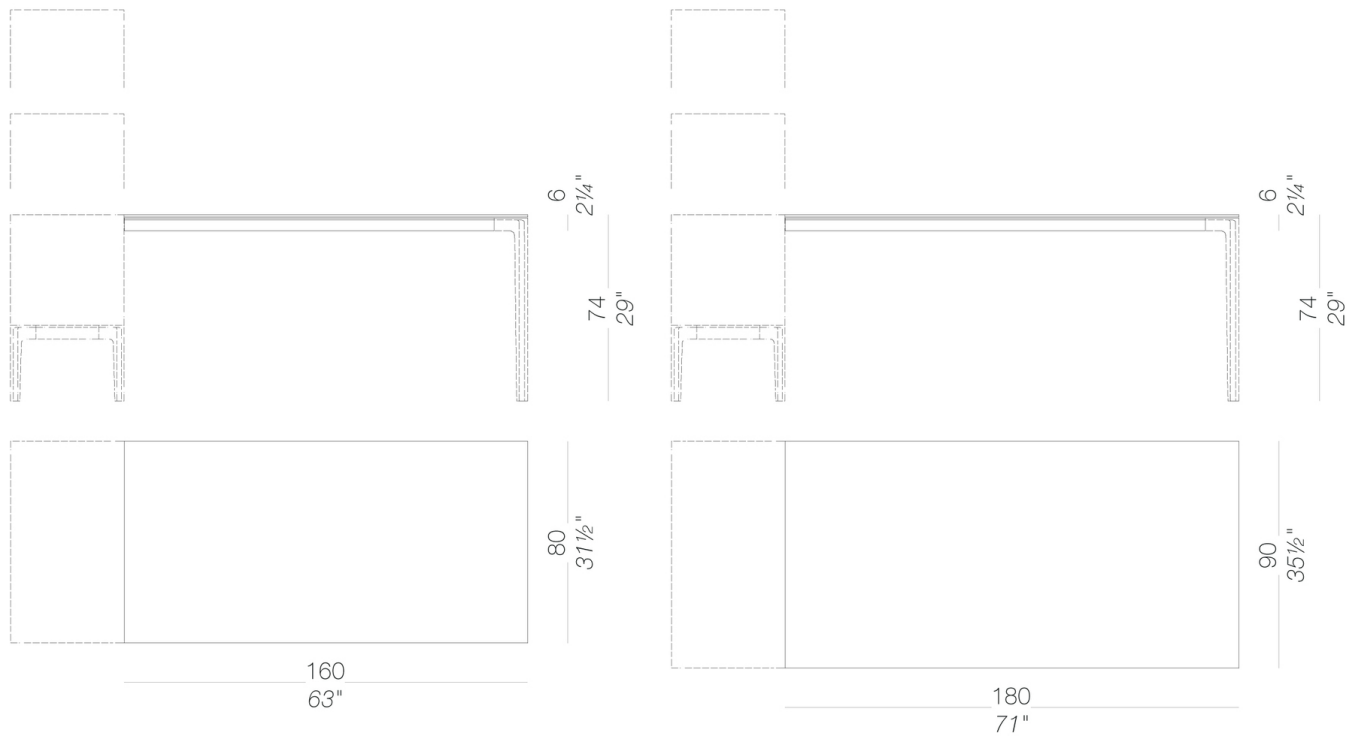

ADD SYSTEM

Francesco Rota | 2016

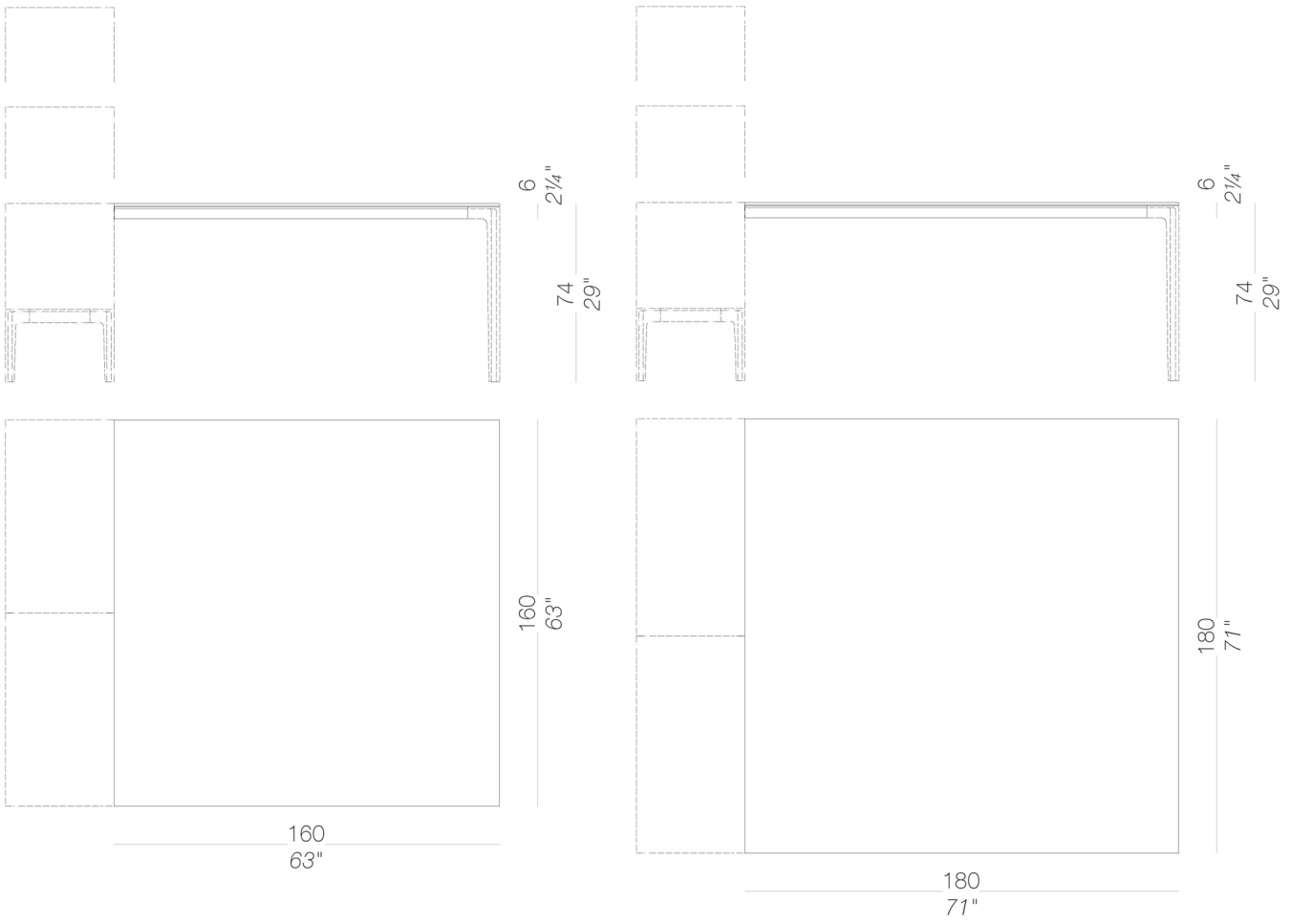

ADD SYSTEM

Francesco Rota | 2016

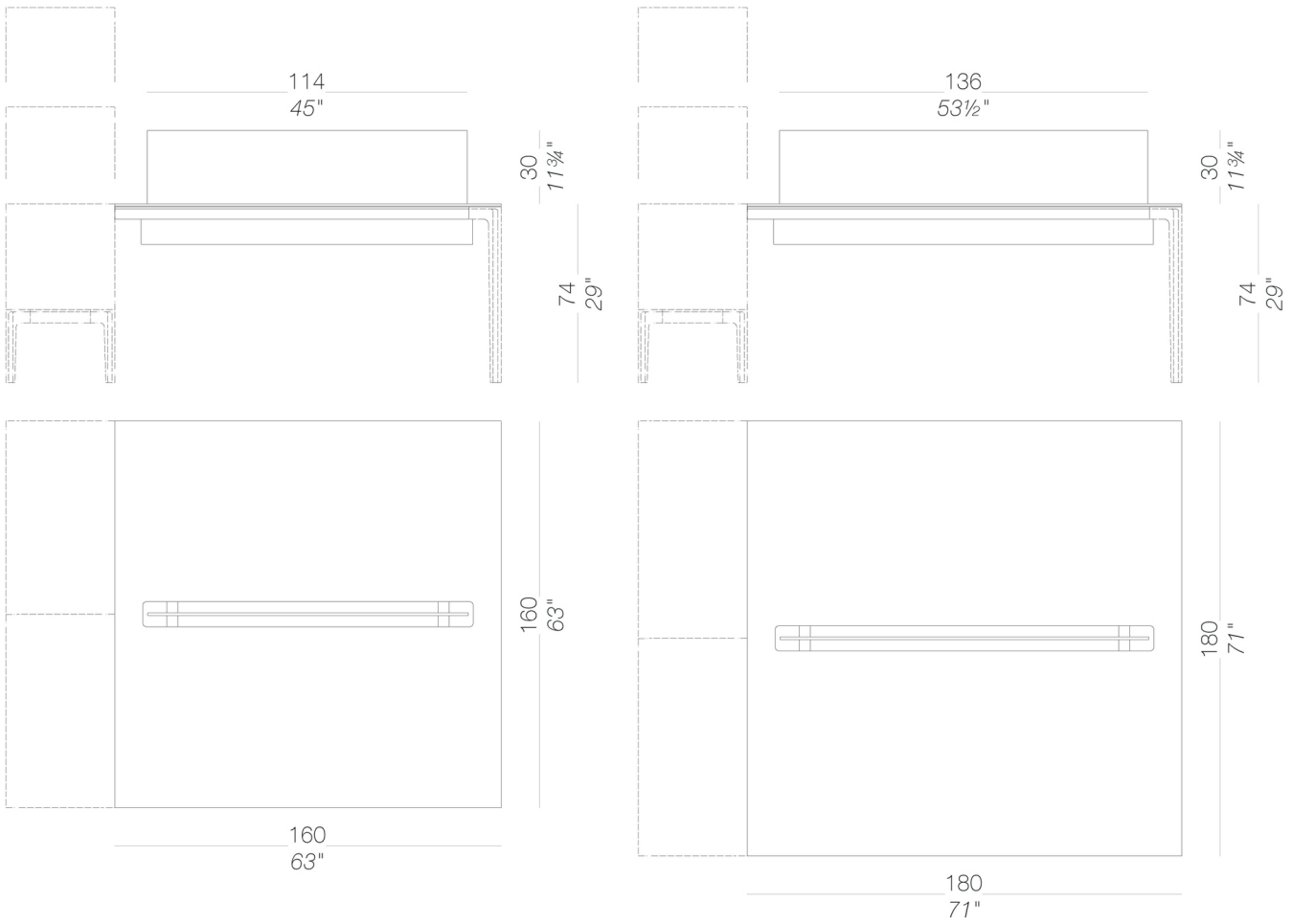

partition panel

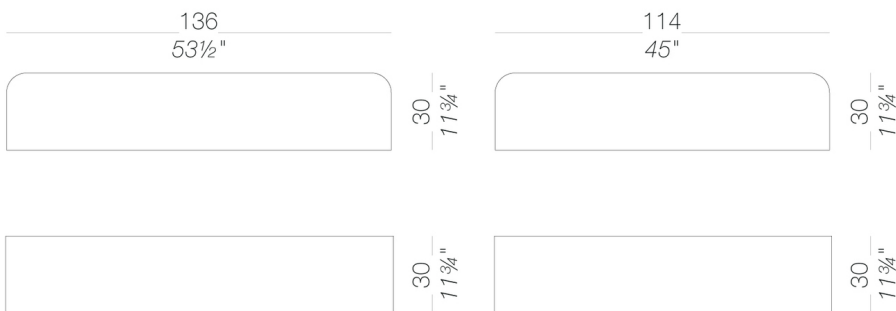

ADD SYSTEM

Francesco Rota | 2016

frame



powder coating
black
1 Colors

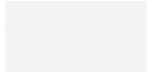

powder coating
white
1 Colors

top



HPL 10 mm
black HPL fenix
1 Colors



HPL 10 mm
white HPL fenix
1 Colors

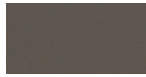

HPL 10 mm
HPL fenix grigio
Londra
1 Colors



HPL 10 mm
HPL fenix rosso
Jaipur
1 Colors



wood
blached oak
1 Colors

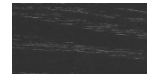

wood
black open pore
1 Colors

modesty panel



HPL 10 mm
black HPL fenix
1 Colors



HPL 10 mm
white HPL fenix
1 Colors

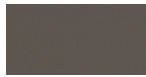

HPL 10 mm
HPL fenix grigio
Londra
1 Colors



HPL 10 mm
HPL fenix rosso
Jaipur
1 Colors

partition panel



HPL 10 mm
black HPL fenix
1 Colors

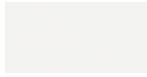

HPL 10 mm
white HPL fenix
1 Colors

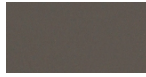

HPL 10 mm
HPL fenix grigio
Londra
1 Colors



HPL 10 mm
HPL fenix rosso
Jaipur
1 Colors



wood
blached oak
1 Colors

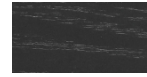

wood
black open pore
1 Colors

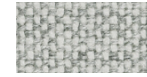

fabric
Hallingdal 65 -
Grade C
58 Colors



fabric
Canvas 2 - Grade C
45 Colors



fabric
Steelcut Trio 3 -
Grade D
54 Colors



fabric
Remix 3 - Grade C
72 Colors



fabric
Clara 2 - Grade C
24 Colors



fabric
Fiord 2 - Grade C
39 Colors



fabric
Divina MD - Grade
27 Colors



fabric
Divina Melange 3 -
Grade D
38 Colors



fabric
Tonica 2 - Grade C
39 Colors



fabric
Medley - Grade A
37 Colors



fabric
Jet - Grade A
66 Colors

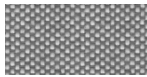

fabric
Maya - Grade A
43 Colors



fabric
Lapalma Smart -
Grade C
18 Colors

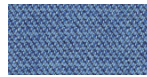

fabric
Capture - Grade B
43 Colors



fabric
Crisp - Grade B
40 Colors



fabric
Nattè - Grade B
30 Colors



fabric
Ilris - Grade B
24 Colors



fabric
Steelcut 3 - Grade D
40 Colors



fabric
Grain - Grade B
50 Colors



fabric
Re-wool - Grade C
21 Colors

consult the portfolio for the range of colors, fabrics, eco-leather, soft-leather.

use and maintenance instructions

Clean all parts in wood, leather, fabric and metal with a damp cloth or a diluted neutral cleaner. Do not use cleaners with alcohol, bleach, solvent or abrasive products. Any liquid spilt on the product must be wiped up immediately. When lifting or moving the product, hold it on the structure and not under the seat. The product should not be subjected to unbalanced weights, as it is designed for a proper rest on the foothold (on four legs or on the base). Our company relieves from any responsibility in case of damage caused to fragile floors. Avoid any improper use of the product: do not step on the product, on the footrest or on the armrests. Avoid any movements that could compromise the proper functionality of the product or the safety of the users. Wood and leather, being natural materials, could be easily damaged. Small impurities or imperfections are within quality standard range. Do not expose the product to weather conditions or atmospheric agents, nor to heat sources over 40°C. Also products for outdoor use could be afflicted by atmospheric agents. The product could undergo possible exterior changes due to particular exposure to heat, humidity and saltiness. An appropriate and frequent maintenance and cleaning of the product enhances its durability. The product could change colour and shade, if exposed to direct sunlight. Maintenance has to be carried out by experienced staff. Dispose of the package only after assembling the product, in order to avoid the loss of ironmongery and components. Once the product has been dismantled, the product itself or its components must be given to the public garbage disposal system, according to the legislation in force.

ADD S

Francesco Rota | 2016



ADD S

Francesco Rota | 2016

Documents, books and objects. Memories and visions of the future. Any period of design can find a space in the ADD system storage units. In line with the inventive creativity of seating, metal units can be arranged and combined with tables in a versatile way, thus creating work stations. Double-sided, open or closed with drawers and doors, these furniture units easily furnish the centre of a room and its walls. The same flexibility can be found with finishes and colours that enhance monochrome rigour or add contrasting effects with the different shades of seating and cushions.



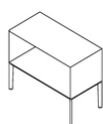

S — open

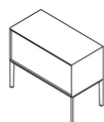

S — flap door

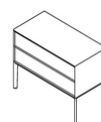

S — two drawers



M — open

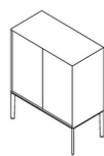

M — doors

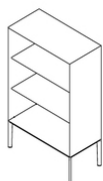

L — open

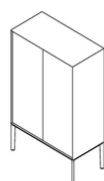

L — doors



L – doors + M – open

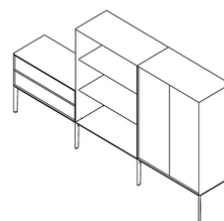

S – two drawers + L – open + L – doors

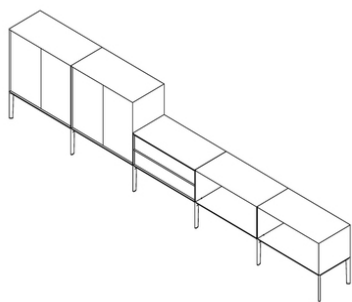

M – doors double + S – two drawers + S – open double

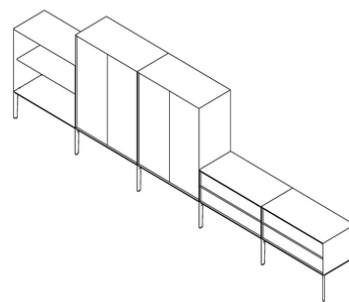

M – open + L – doors double + S – two drawers double

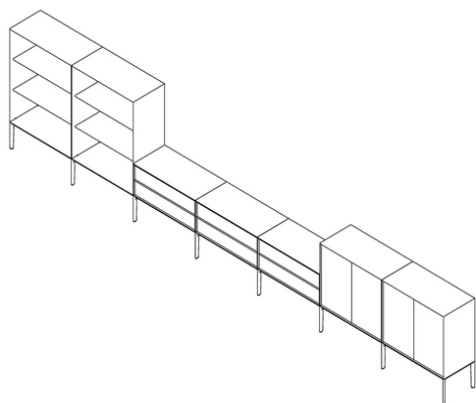

L – open double + S – two drawers triple + M – doors double

ADD S

Francesco Rota | 2016

Modular system with storage units and seating, with frame in extrusion of aluminium and legs in die cast aluminium, all powder coated. Storages, drawers, backs and doors in several finishes, top of tables in HPL Fenix®. Seating with elastic support, cushions in molded fire retardant foam with polyester fiber and upholstered with removable fabric, leather or eco-leather. ADD storage System can be combined with the ADD table system and ADD seating system.

legs



frame

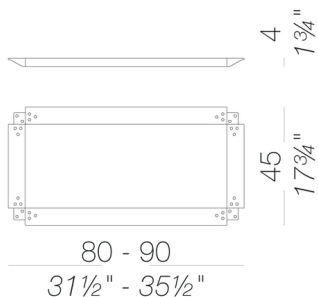

top for small table

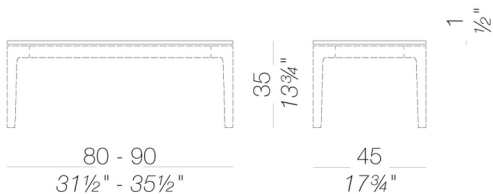

cabinets

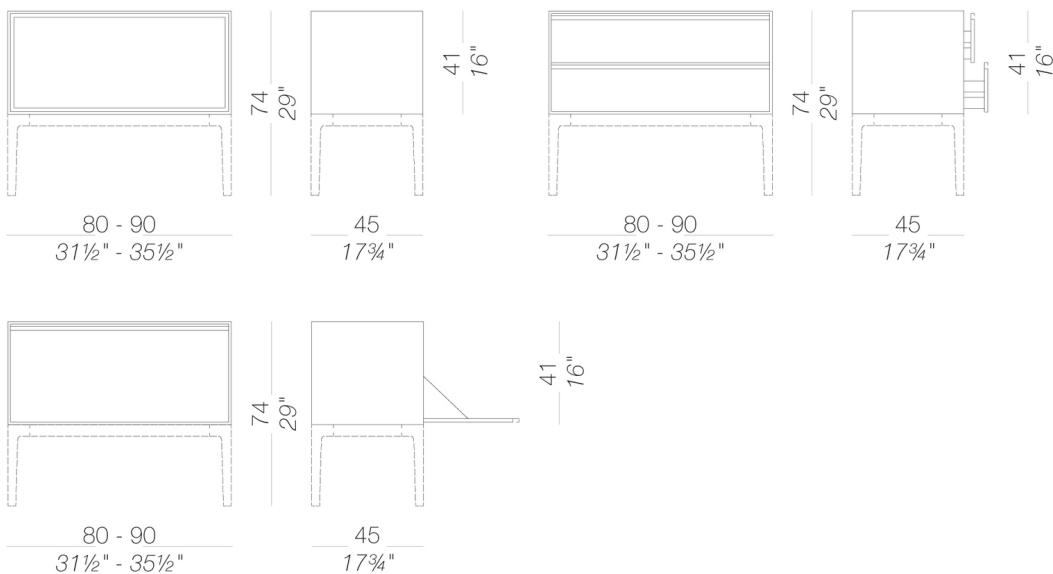

ADD S

Francesco Rota | 2016

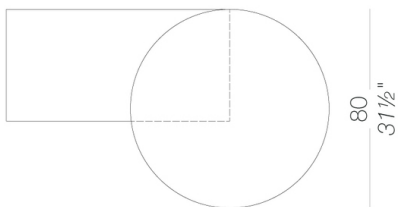
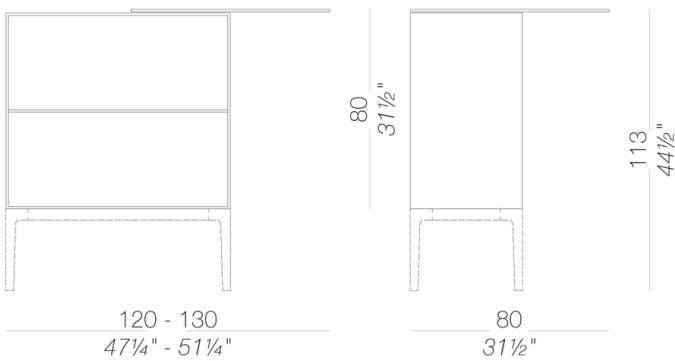
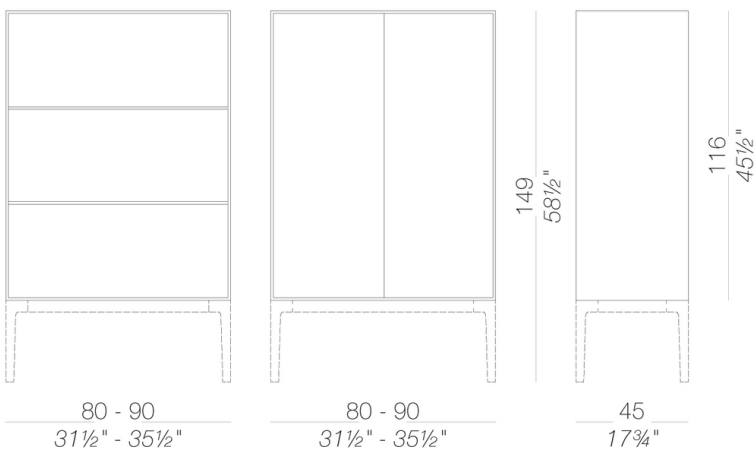
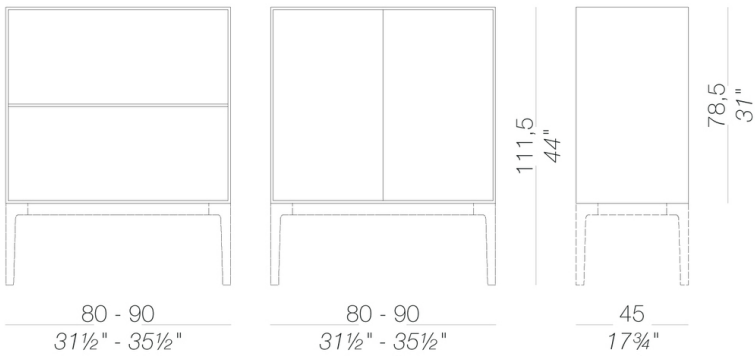

ADD S

Francesco Rota | 2016

frame for seat

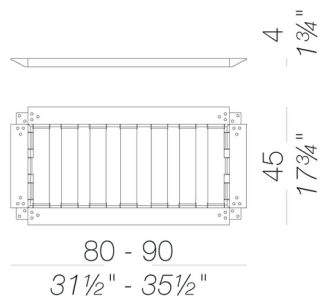

cushion

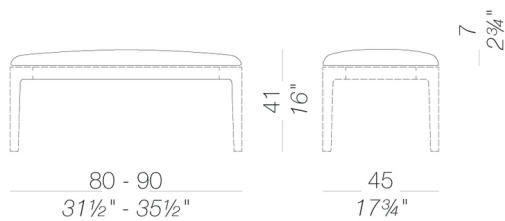

drawer unit on castors

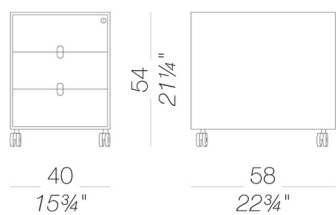

ADD S

Francesco Rota | 2016

frame



powder coating
black
1 Colors



powder coating
white
1 Colors

drawer unit on castors



powder coating
black
1 Colors

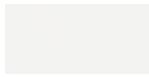

powder coating
white
1 Colors

upholstery for drawers and doors



wood
blanch oak
1 Colors



lacquered
lacquered
2 Colors

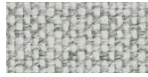

fabric
Hallingdal 65 -
Grade C
58 Colors



fabric
Canvas 2 - Grade C
45 Colors



fabric
Steelcut Trio 3 -
Grade D
54 Colors



fabric
Remix 3 - Grade C
72 Colors

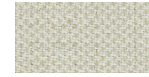

fabric
Clara 2 - Grade C
24 Colors



fabric
Fiord 2 - Grade C
39 Colors



fabric
Divina MD - Grade D
27 Colors



fabric
Divina Melange 3 -
Grade D
38 Colors



fabric
Tonica 2 - Grade C
39 Colors



fabric
Medley - Grade A
37 Colors

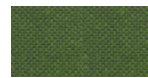

fabric
Jet - Grade A
66 Colors

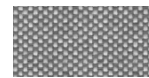

fabric
Maya - Grade A
43 Colors

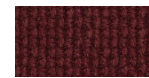

fabric
Lapalma Smart -
Grade C
18 Colors

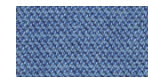

fabric
Capture - Grade B
43 Colors



fabric
Crisp - Grade B
40 Colors

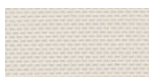

fabric
Nattè - Grade B
30 Colors

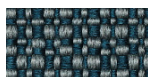

fabric
Iliris - Grade B
24 Colors



fabric
Steelcut 3 - Grade D
40 Colors



ecoleather
GRIMM FR - Grade
A
32 Colors



ecoleather
Valencia - Grade B
66 Colors

backs



powder coating
black
1 Colors

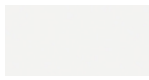

powder coating
white
1 Colors



wood
blanched oak
1 Colors



powder coating
white
1 Colors



lacquered
lacquered
2 Colors



metal
perforated metal
2 Colors

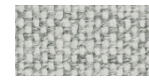

fabric
Hallingdal 65 -
Grade C
58 Colors



fabric
Canvas 2 - Grade C
45 Colors



fabric
Steelcut Trio 3 -
Grade D
54 Colors



fabric
Remix 3 - Grade C
72 Colors



fabric
Clara 2 - Grade C
24 Colors



fabric
Fiord 2 - Grade C
39 Colors



fabric
Divina MD - Grade
27 Colors



fabric
Divina Melange 3 -
Grade D
38 Colors

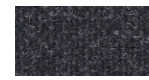

fabric
Tonica 2 - Grade C
39 Colors



fabric
Medley - Grade A
37 Colors



fabric
Jet - Grade A
66 Colors

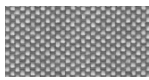

fabric
Maya - Grade A
43 Colors

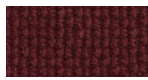

fabric
Lapalma Smart -
Grade C
18 Colors

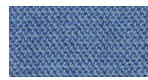

fabric
Capture - Grade B
43 Colors



fabric
Crisp - Grade B
40 Colors



fabric
Nattè - Grade B
30 Colors

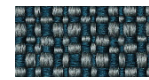

fabric
Iris - Grade B
24 Colors



fabric
Steelcut 3 - Grade D
40 Colors



ecoleather
Valencia - Grade B
66 Colors



ecoleather
GRIMM FR - Grade
A
32 Colors

ADD S

Francesco Rota | 2016

cushion

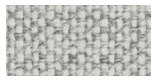

fabric
Hallingdal 65 -
Grade C
58 Colors



fabric
Canvas 2 - Grade C
45 Colors



fabric
Steelcut Trio 3 -
Grade D
54 Colors

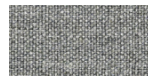

fabric
Remix 3 - Grade C
72 Colors



fabric
Fiord 2 - Grade C
39 Colors



fabric
Clara 2 - Grade C
24 Colors



fabric
Divina MD - Grade
27 Colors



fabric
Divina Melange 3 -
Grade D
38 Colors



fabric
Tonica 2 - Grade C
39 Colors



fabric
Medley - Grade A
37 Colors



fabric
Jet - Grade A
66 Colors

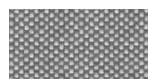

fabric
Maya - Grade A
43 Colors

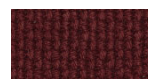

fabric
Lapalma Smart -
Grade C
18 Colors

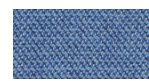

fabric
Capture - Grade B
43 Colors



fabric
Crisp - Grade B
40 Colors



ecoleather
GRIMM FR - Grade
A
32 Colors

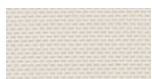

fabric
Nattè - Grade B
30 Colors



fabric
Iris - Grade B
24 Colors



fabric
Steelcut 3 - Grade D
40 Colors



ecoleather
Valencia - Grade B
66 Colors



fabric
Grain - Grade. B
50 Colors



fabric
Re-wool - Grade C
21 Colors

top



HPL 10 mm
HPL fenix
2 Colors



HPL 10 mm
HPL fenix
2 Colors

consult the portfolio for the range of colors, fabrics, eco-leather, soft-leather.

use and maintenance instructions

Clean all parts in wood, leather, fabric and metal with a damp cloth or a diluted neutral cleaner. Do not use cleaners with alcohol, bleach, solvent or abrasive products. Any liquid spilt on the product must be wiped up immediately. When lifting or moving the product, hold it on the structure and not under the seat. The product should not be subjected to unbalanced weights, as it is designed for a proper rest on the foothold (on four legs or on the base). Our company relieves from any responsibility in case of damage caused to fragile floors. Avoid any improper use of the product: do not step on the product, on the footrest or on the armrests. Avoid any movements that could compromise the proper functionality of the product or the safety of the users. Wood and leather, being natural materials, could be easily damaged. Small impurities or imperfections are within quality standard range. Do not expose the product to weather conditions or atmospheric agents, nor to heat sources over 40°C. Also products for outdoor use could be afflicted by atmospheric agents. The product could undergo possible exterior changes due to particular exposure to heat, humidity and saltiness. An appropriate and frequent maintenance and cleaning of the product enhances its durability. The product could change colour and shade, if exposed to direct sunlight. Maintenance has to be carried out by experienced staff. Dispose of the package only after assembling the product, in order to avoid the loss of ironmongery and components. Once the product has been dismantled, the product itself or its components must be given to the public garbage disposal system, according to the legislation in force.