

LEM

Shin & Tomoko Azumi | 2000



LEM

Shin & Tomoko Azumi | 2000

In 1969, man landed on the moon in the LEM (Lunar Excursion Module). In 2000, at the turn of the millennium, the LEM stool was created and became one of the symbols of Lapalma's style. The same lightness, the same absence of gravity, which, in the void created by the design, fosters its relationship with the environment. And like the Apollo 11, as it could not bear unnecessary weights, this amazing chair incorporated all functions in a highly elegant minimalist profile. Only the essential, the rest stayed on the ground.



LEM

Shin & Tomoko Azumi | 2000



S79 | Height-adjustable stool stool H55 ÷ 67 mat chromed gas lift

Stool with swivel seat and adjustable height with metal frame mat chromed and base covered by a stainless steel sheet Aisi304 "linen fabric" pattern or entirely powder coated. Mat chromed piston. Seat in plywood in several finishes. Felt under the base.

TEST DIN 68 877/81 5.6

TEST 1 IM - Valencia

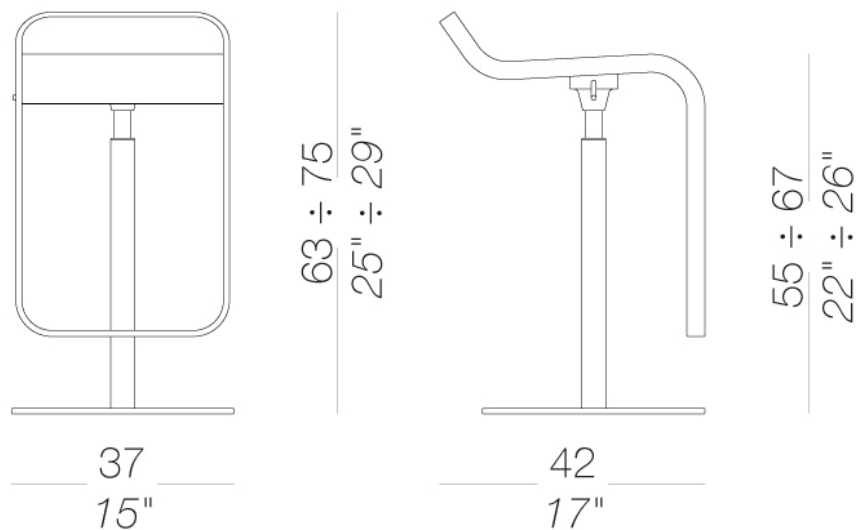

LEM

Shin & Tomoko Azumi | 2000

S79 | Height-adjustable stool Stool H55÷67 powder coated gas lift

Stool with swivel seat and adjustable height with metal frame powder coated. Powder coated piston. Seat in plywood in several finishes. Felt under the base.

TEST DIN 68 877/81 5.6

TEST 1 IM - Valencia

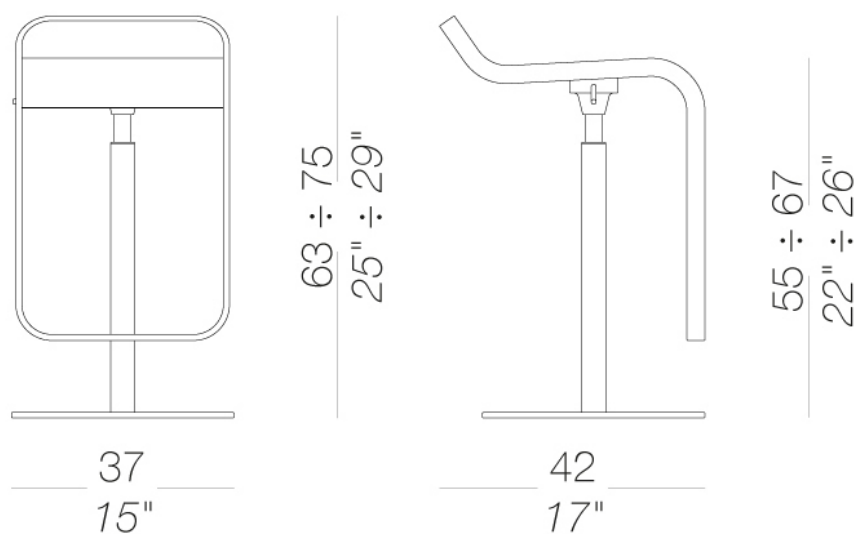

LEM

Shin & Tomoko Azumi | 2000

S80 | Height-adjustable stool Stool H66÷79 mat chromed gas lift

Stool with swivel seat and adjustable height with metal frame mat chromed and base covered by a stainless steel sheet Aisi304 "linen fabric" pattern or entirely powder coated. Mat chromed piston. Seat in plywood in several finishes. Felt under the base.

TEST DIN 68 877/81 5.6

TEST 1 IM - Valencia

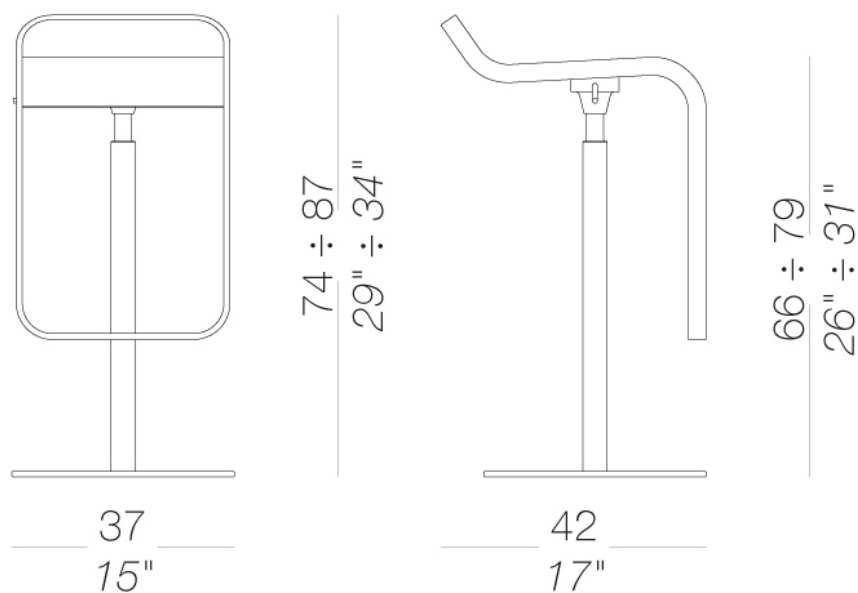

LEM

Shin & Tomoko Azumi | 2000

S80 | Height-adjustable stool Stool H66÷79 powder coated gas lift

Stool with swivel seat and adjustable height with metal frame powder coated. Powder coated piston. Seat in plywood in several finishes. Felt under the base.

TEST DIN 68 877/81 5.6

TEST 1 IM - Valencia

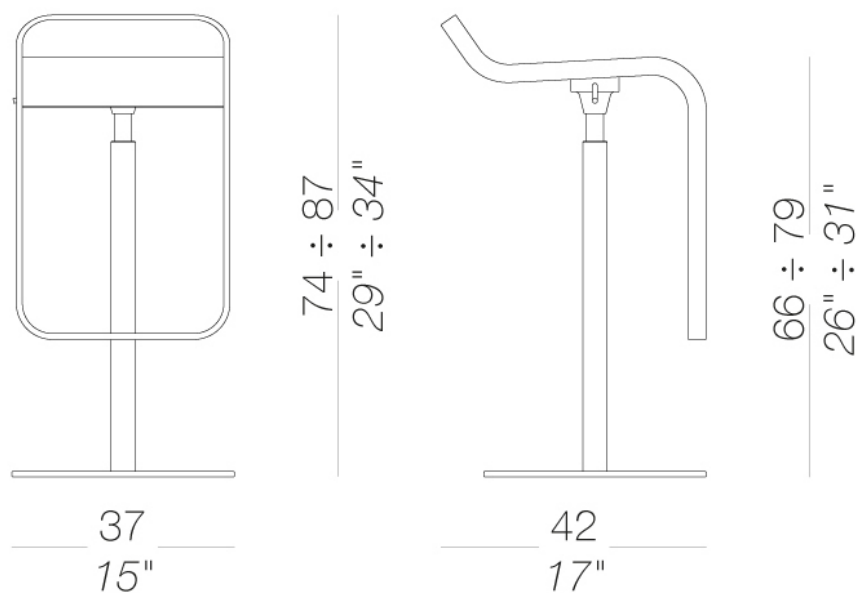

LEM

Shin & Tomoko Azumi | 2000

| S81 Stool H80

Stool with fix height, swivel seat with metal frame mat chromed and base covered by a stainless steel sheet Aisi304 "linen fabric" pattern or entirely powder coated. Seat in plywood in several finishes. Felt under the base. Also available with self-return mechanism.

TEST EN 1728:2000 6.2.1-6.2.2 - EN 15373:2007 - L3 severe
TEST DIN 68 877/81 5.6

TEST 1 IM - Valencia

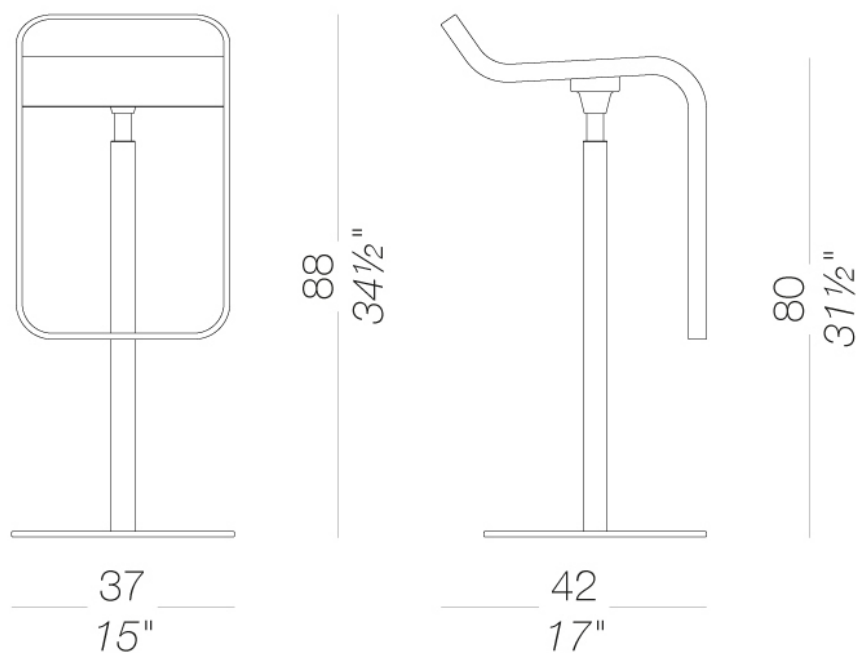

LEM

Shin & Tomoko Azumi | 2000

| S83 Stool H66÷79 self-returning seat mat chromed gas lift

Stool with swivel seat and adjustable height with self-returning mechanism to the original height and to the front position. Metal frame mat chromed and base covered by a stainless steel sheet Aisi304 "linen fabric" pattern or entirely powder coated. Mat chromed piston. Seat in plywood in several finishes. Felt under the base. Also available small base Ø 20 cm. for floor fixing.

TEST DIN 68 877/81 5.6



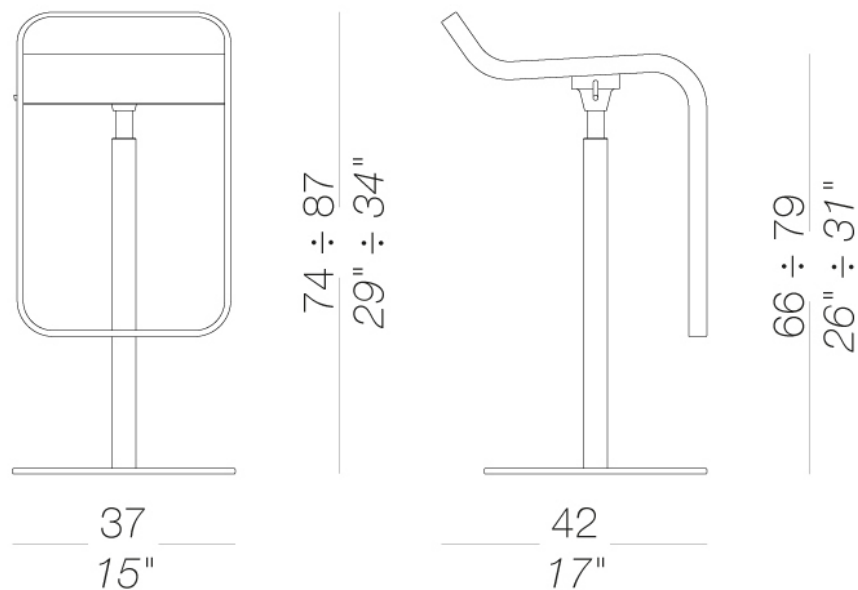





TEST 1 IM - Valencia

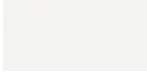











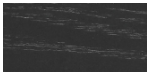

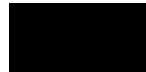
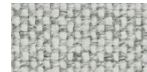





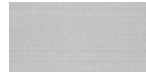

LEM

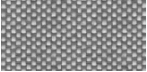
Shin & Tomoko Azumi | 2000

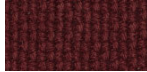
frame

							
powder coating black 1 Colors	powder coating white 1 Colors	powder coating perla 1 Colors	powder coating celeste 1 Colors	powder coating mattone 1 Colors	powder coating caffè 1 Colors	powder coating oliva 1 Colors	powder coating tortora 1 Colors
							
metal mat chromed 1 Colors							

seat

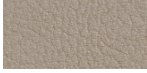
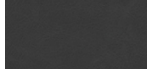
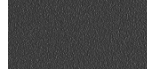
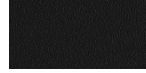
							
wood blanch oak 1 Colors	wood black open pore 1 Colors	wood oak dark walnut 1 Colors	lacquered lacquered 8 Colors	laminate fenix 9/10 2 Colors	fabric Hallingdal 65 58 Colors	fabric Canvas 2 45 Colors	fabric Steelcut Trio 3 54 Colors
							
fabric Remix 3 72 Colors	fabric Clara 2 24 Colors	fabric Fiord 2 39 Colors	fabric Divina MD 27 Colors	metal stainless steel 1 Colors	fabric Divina Melange 3 38 Colors	fabric Tonica 2 39 Colors	fabric Medley 37 Colors
							
fabric Maya 43 Colors	fabric Jet 66 Colors	fabric Lapalma Smart 18 Colors	fabric Capture 43 Colors	fabric Crisp 40 Colors	fabric Nattè 23 Colors	fabric Iris 24 Colors	fabric Steelcut 3 37 Colors
							
ecoleather GRIMM FR 24 Colors	ecoleather Valencia 59 Colors	leather leather 7 Colors	plastics grey polyurethane 1 Colors	plastics black polyurethane 1 Colors			

consult the portfolio for the range of colors, fabrics, eco-leather, soft-leather.

use and maintenance instructions

Clean all parts in wood, leather, fabric and metal with a damp cloth or a diluted neutral cleaner. Do not use cleaners with alcohol, bleach, solvent or abrasive products. Any liquid spilt on the product must be wiped up immediately. When lifting or moving the product, hold it on the structure and not under the seat. The product should not be subjected to unbalanced weights, as it is designed for a proper rest on the foothold (on four legs or on the base). Our company relieves from any responsibility in case of damage caused to fragile floors. Avoid any improper use of the product: do not step on the product, on the footrest or on the armrests. Avoid any movements that could compromise the proper functionality of the product or the safety of the users. Wood and leather, being natural materials, could be easily damaged. Small impurities or imperfections are within quality standard range. Do not expose the product to weather conditions or atmospheric agents, nor to heat sources over 40°C. Also products for outdoor use could be afflicted by atmospheric agents. The product could undergo possible exterior changes due to particular exposure to heat, humidity and saltiness. An appropriate and frequent maintenance and cleaning of the product enhances its durability. The product could change colour and shade, if exposed to direct sunlight. Maintenance has to be carried out by experienced staff. Dispose of the package only after assembling the product, in order to avoid the loss of ironmongery and components. Once the product has been dismantled, the product itself or its components must be given to the public garbage disposal system, according to the legislation in force.

LEM 

Shin & Tomoko Azumi | 2000





Shin & Tomoko Azumi | 2000

Indoors, it is part of the permanent collection of the Victoria & Albert Museum. Outdoors, it follows in the footsteps of the astronauts that conquered the moon in 1969. It is LEM, named after the Lunar Excursion Module, a symbol of Lapalma's style and a masterpiece of lightness and elegance. As with the absence of gravity, a continuous line encloses all functions in minimalist design. It is almost an atlas of every landscape and every encounter.







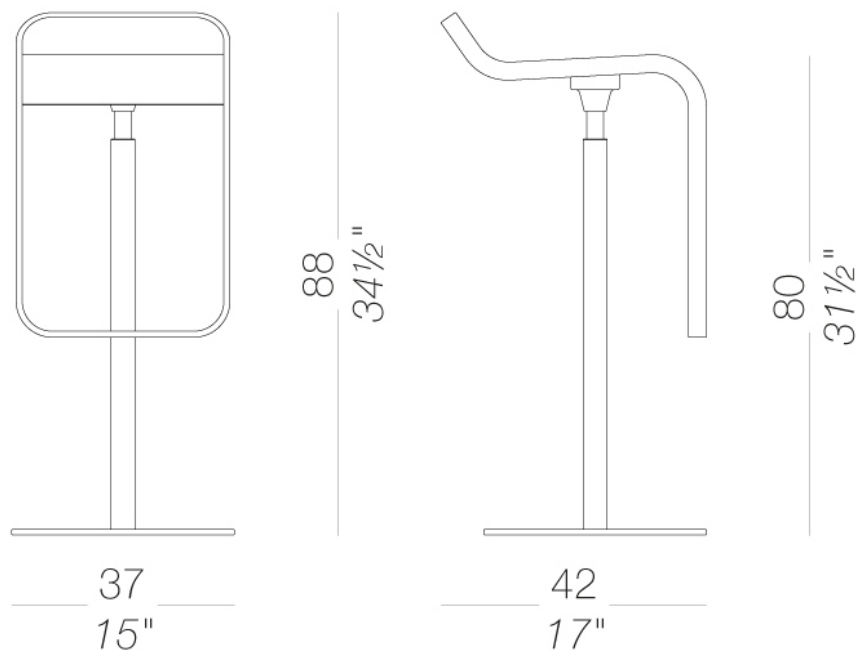

ES81 | outdoor bar stool Swivel stool H80 

Stool with fix height, swivel seat with frame in stainless steel Aisi 316L sandblasted or entirely polyester powder coated. Seat in plywood veneered in Iroko or in integral polyurethane. Rubber glides under the base.

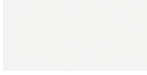

TEST EN 1728:2000 6.2.1-6.2.2 - EN 15373:2007 - L3 severe
TEST DIN 68 877/81 5.6



frame

							
powder coating black 1 Colors	powder coating white 1 Colors	powder coating perla 1 Colors	powder coating celeste 1 Colors	powder coating mattone 1 Colors	powder coating caffè 1 Colors	powder coating oliva 1 Colors	powder coating tortora 1 Colors

seat

		
wood iroko 1 Colors	plastics grey polyurethane 1 Colors	plastics polyurethane black 1 Colors

consult the folder of materials for the range of colors

use and maintenance instructions

Iroko is a naturally weather-resistant wood, as it is rich in tannins, making it ideal for outdoor use. When exposed to light, the colour gradually darkens and every variation in grain shade from brown, chestnut brown to dark grey are characteristic of this wood type. The presence of different grain patterns, knots and natural imperfections guarantee the naturalness of the wood and do not constitute any grounds for claims. To prolong the life of Iroko components, clean surfaces regularly, dry them with a clean cloth and remove any stagnant water. To prevent drying out of the surface, small cracks and/or the formation of mould, we recommend treating the wood once a year with specific products for the maintenance of solid wood (recommended product "OLTS7" water-based natural oil from www.brava.it). Plastic materials, even if intended for outdoor use, may still be attacked over time by particular atmospheric pollutants (e.g. acid rain, high concentration of PM10, nitrogen oxides, hydrocarbons, etc.). Any changes in the surface and in colours may therefore occur under particular conditions of exposure and cannot be considered grounds for any claims.

Do not use detergents containing bleach, hydrochloric acid or products containing chloride on any metal parts. Salt, limescale or acid (from coffee, wine, orange juice, tomato juice, lemon, etc.) may discolour stainless steel parts if they are not promptly cleaned. Products or parts made of stainless steel used near the sea or in interior fittings of swimming pools require more frequent cleaning to remove chloride deposits and prevent corrosion and chemical attack of the external surface. Stains on stainless steel surfaces must be promptly cleaned. If left for a long time they can become permanent.

To prolong the life of the product, clean the surfaces regularly, dry them with a clean cloth and remove any stagnant water, especially if exposed in locations with a high level of humidity or a marine climate.

When not in use, we recommend storing in sheltered places and covering with waterproof protection. In this case, it is advisable to remove the cover and ventilate the product frequently and regularly to avoid the onset of any mould or stains due to damp.

THE WARRANTY WILL NOT COVER DEFECTS OR IMPERFECTIONS RESULTING FROM THE PASSAGE OF TIME OR TO WEAR AND TEAR DUE TO THE NORMAL USE OF THE PRODUCT.